

Focus Dg

1200x1200, 1250x1250, 48"x48"

M203

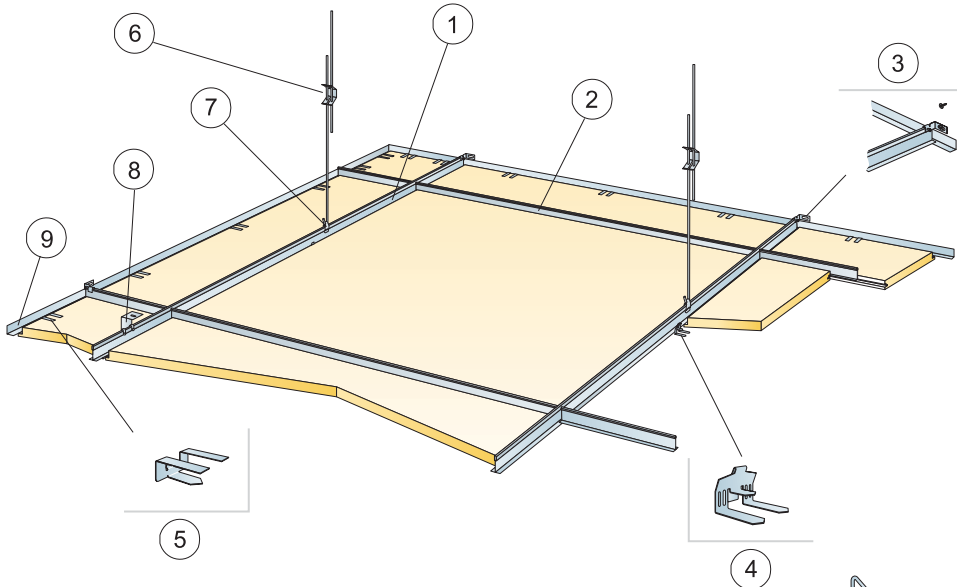

1. Connect T-24 Main runner HD

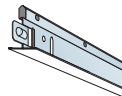

2. Connect T-24 Cross tee, L=1200/1250/48"

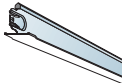

3. Connect Wall bracket

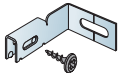

4. Connect Edge clip Dg 0546

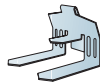

5. Connect Support clip Dg 25 0548

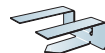

6. Connect Adjustable hanger



7. Connect Hanger clip



8. Connect Direct fixing bracket



9. Connect Angle trim

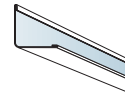

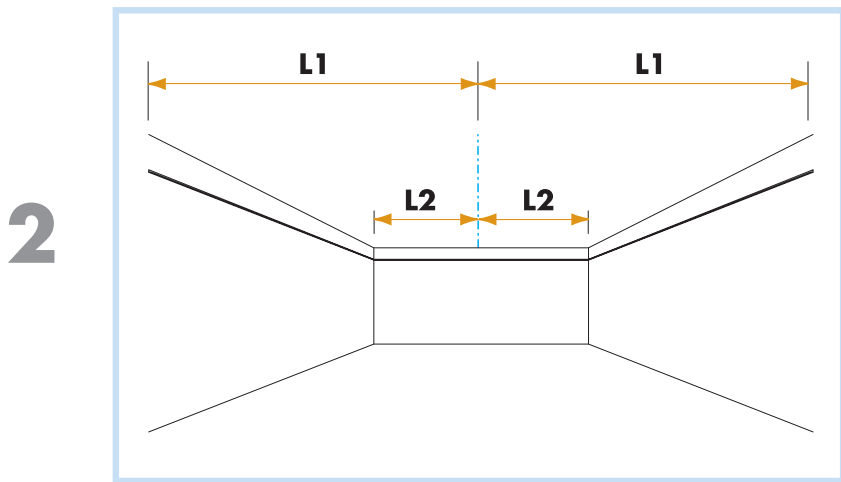
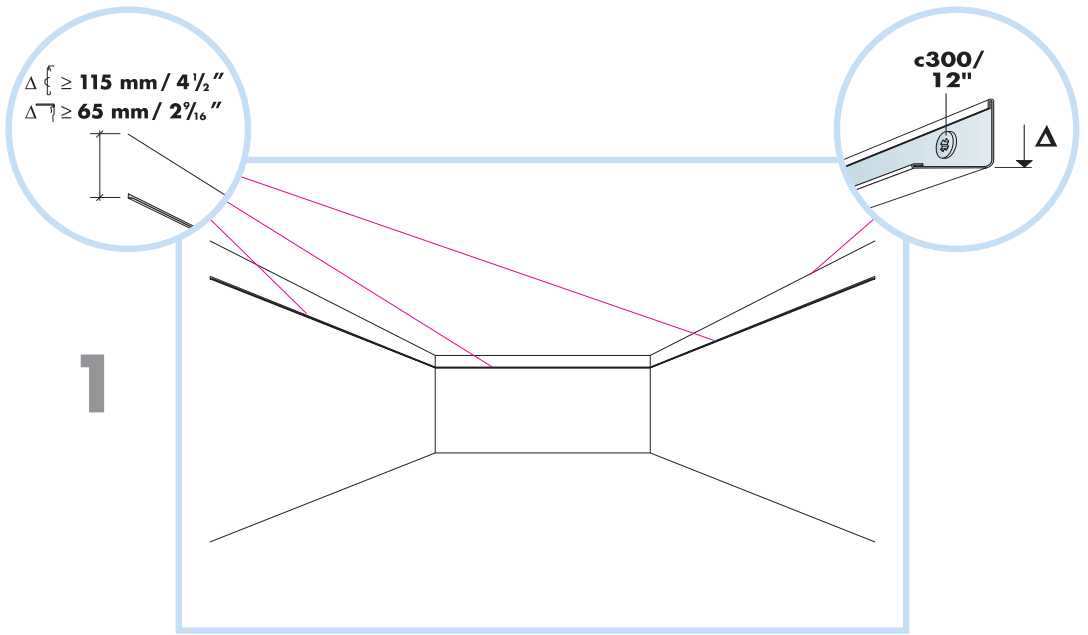

3

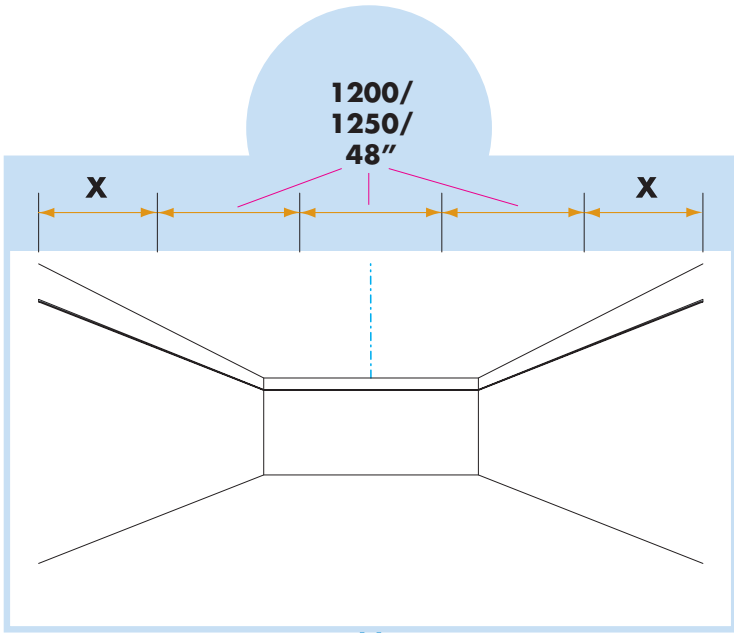

$X \geq 600/24"$

$X < 600/24"$



**600-1200
24"-48"**

**1200/
1250/
48"**

**600-1200
24"-48"**

3¹

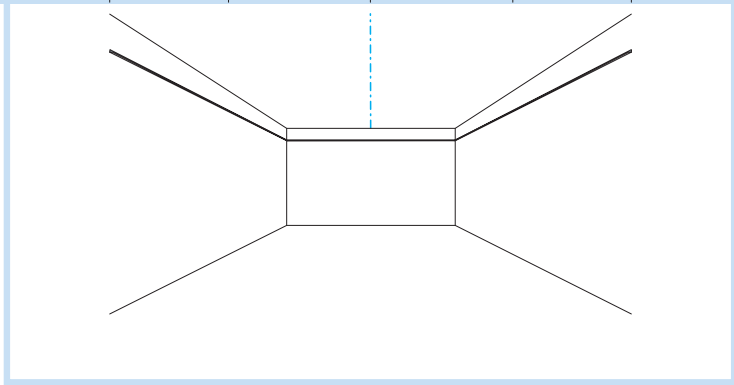

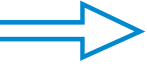

4

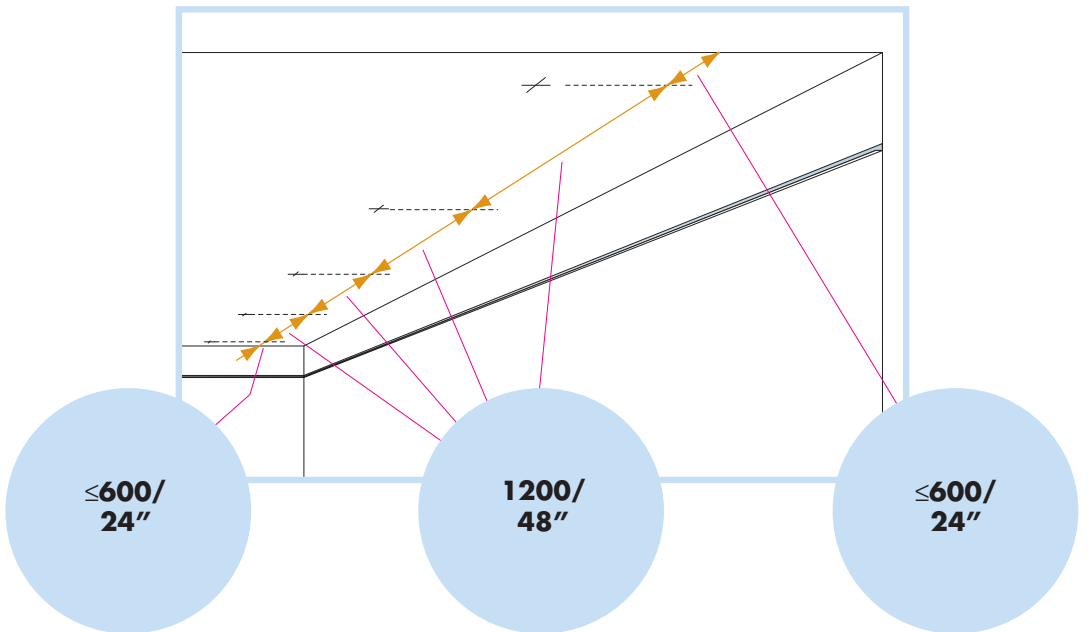
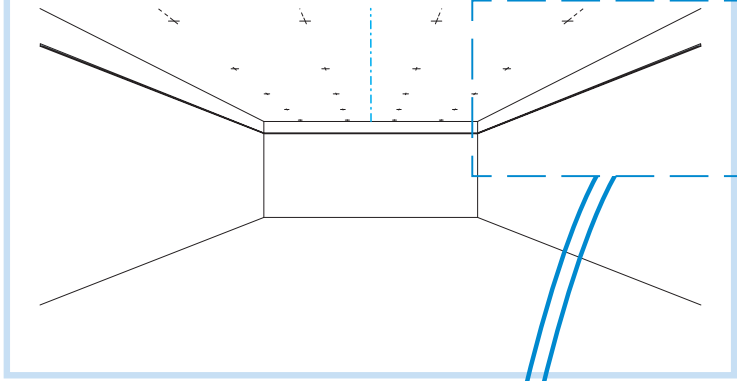
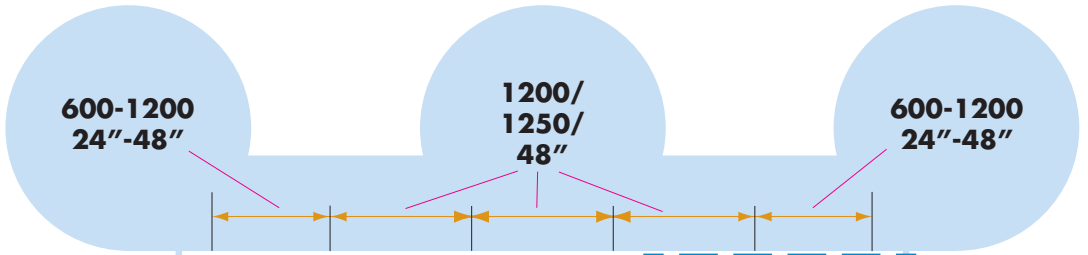

5

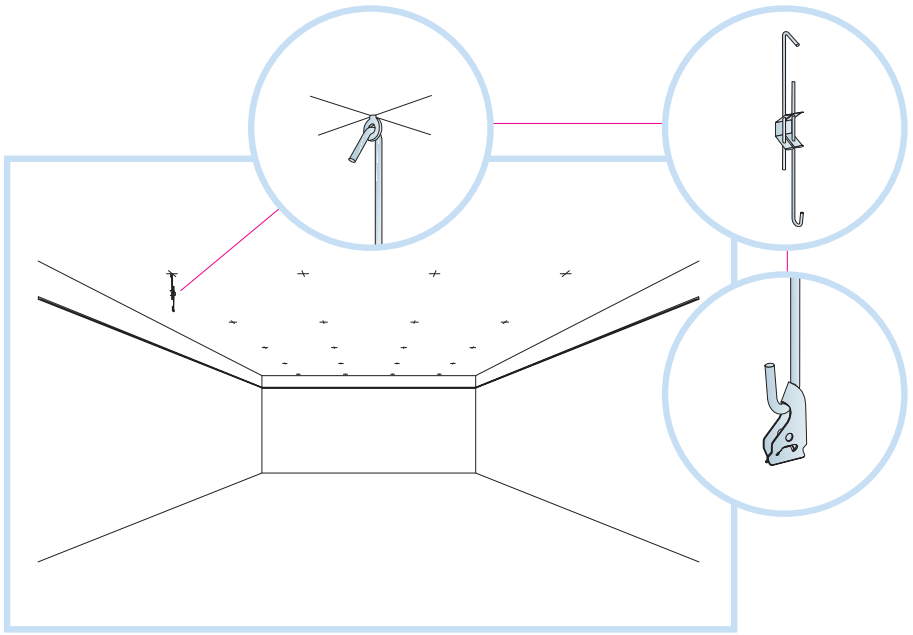

6

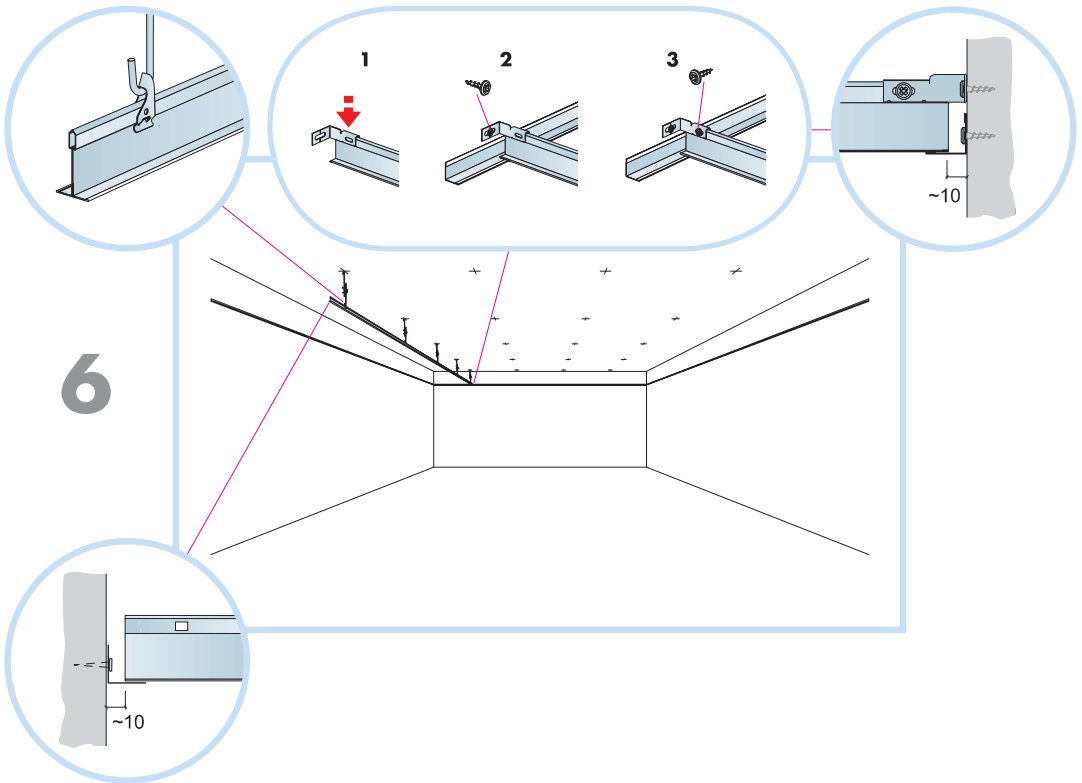

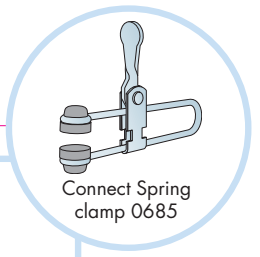
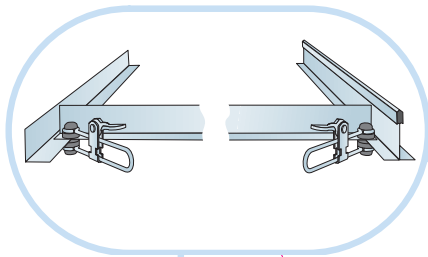

7

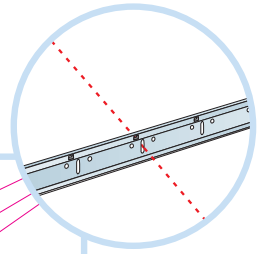
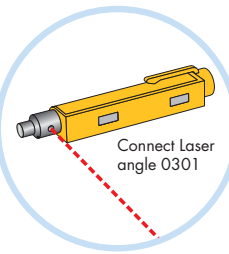
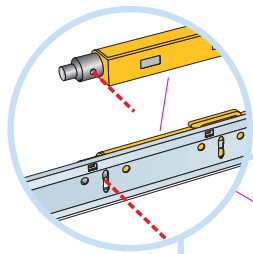
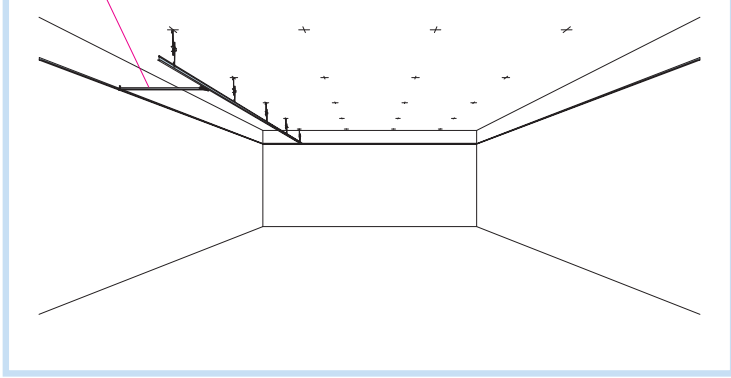

8

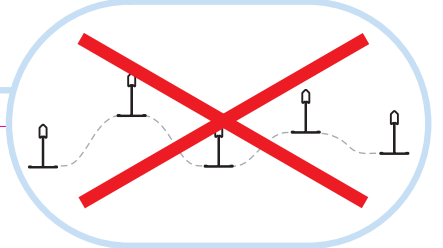
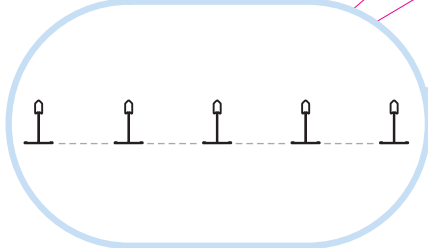
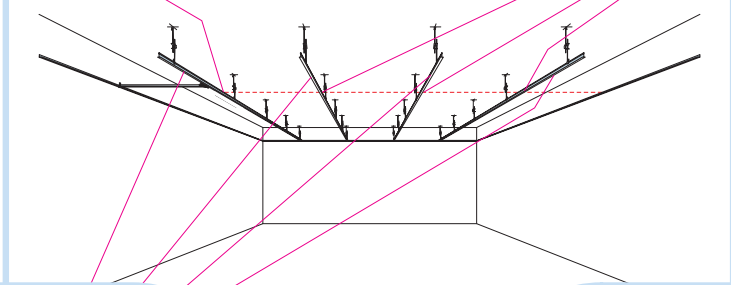

9

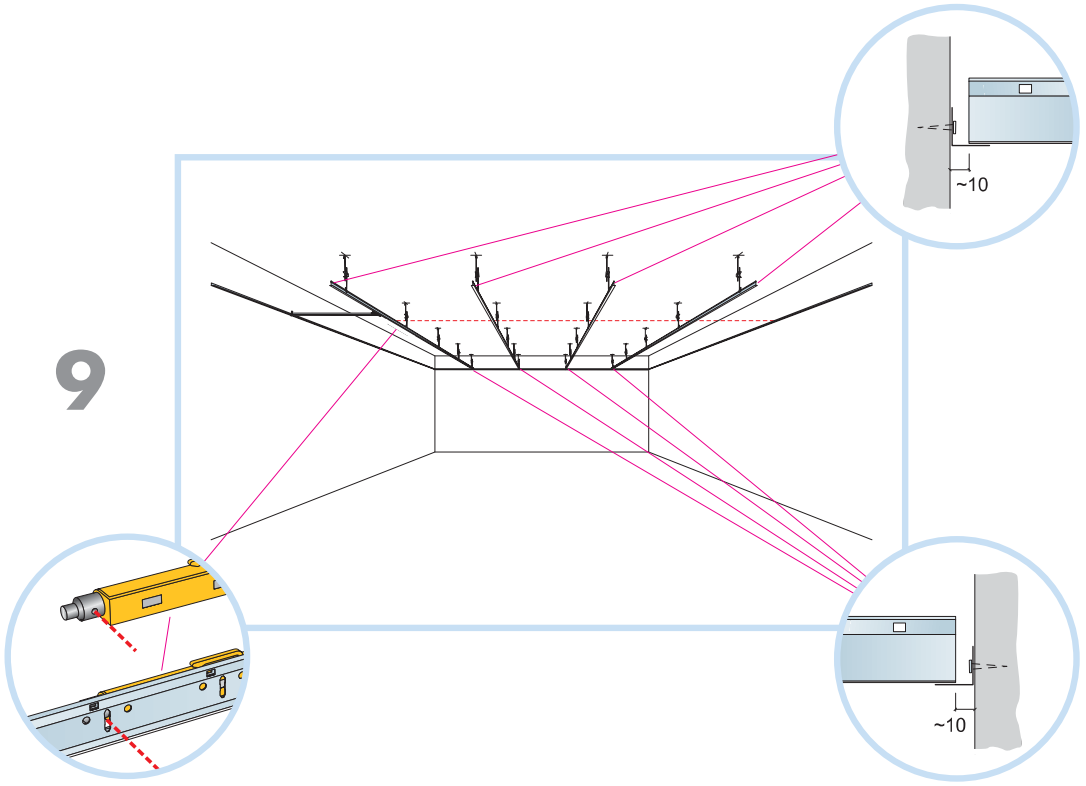

10

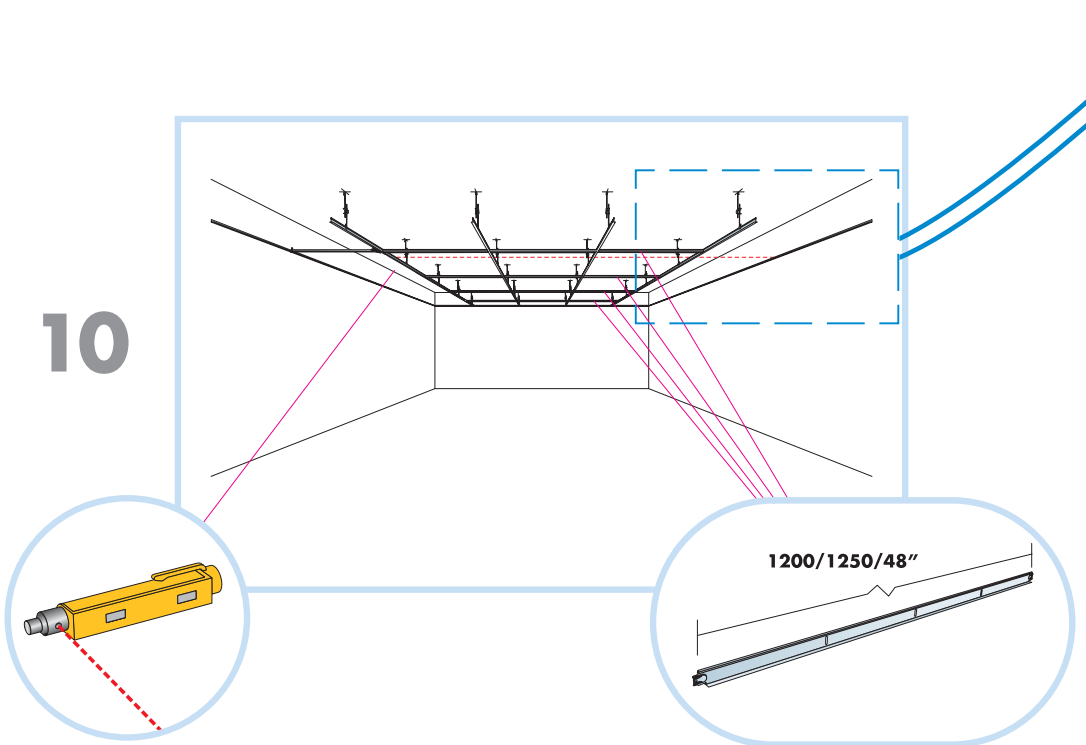

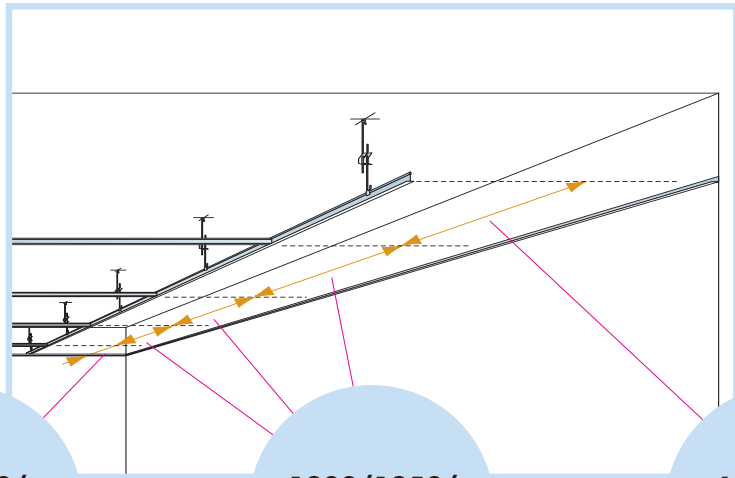

**600-1200/
24-48"**

**1200/1250/
48"**

**600-1200/
24-48"**



11

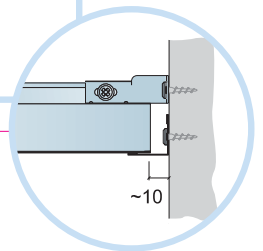
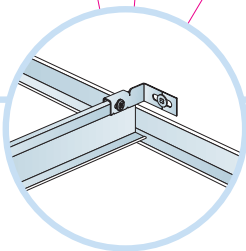
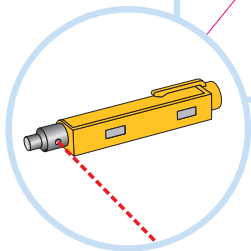
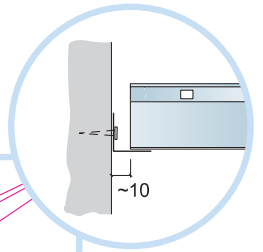
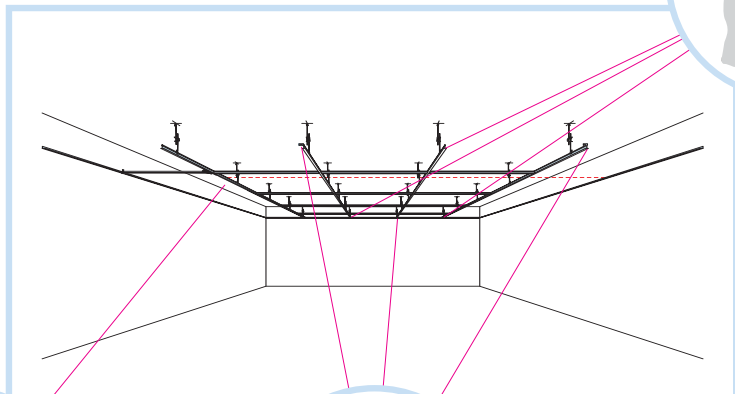

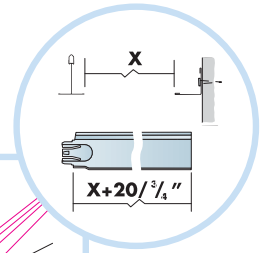
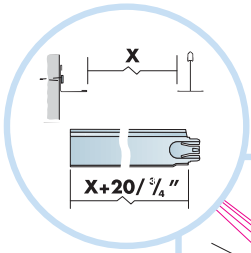

12

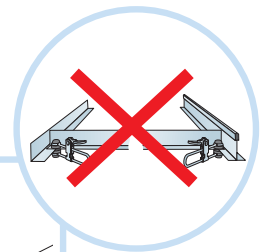
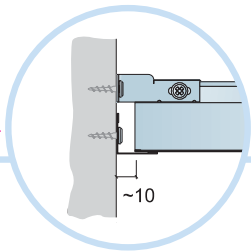
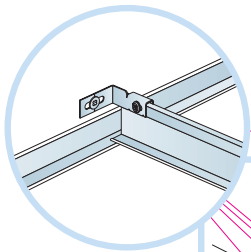
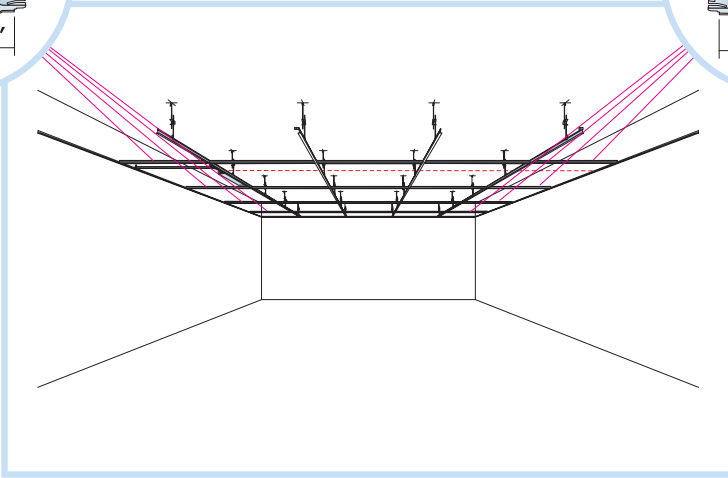

13

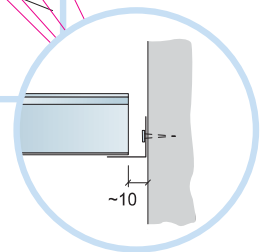
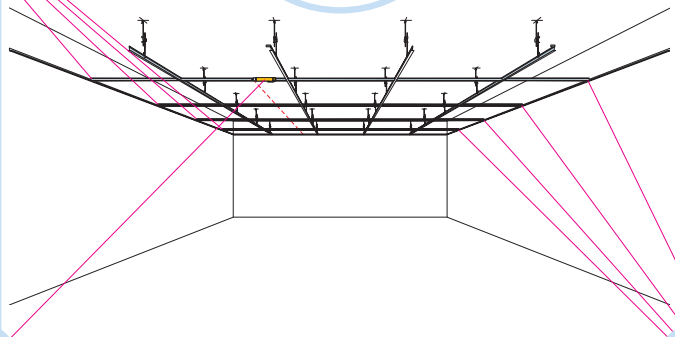
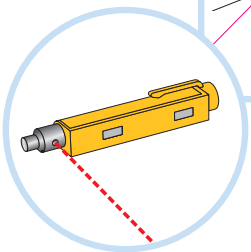

A-A

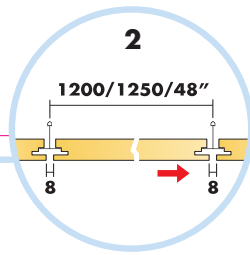
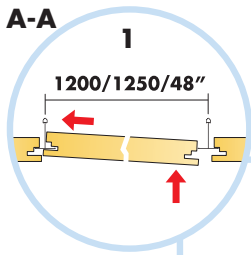

14

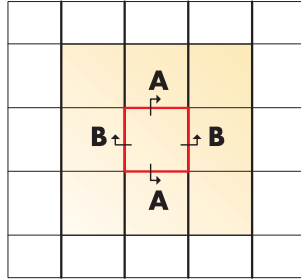

B-B

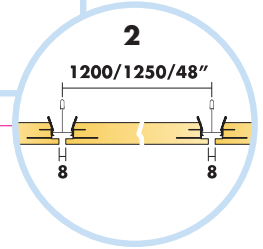
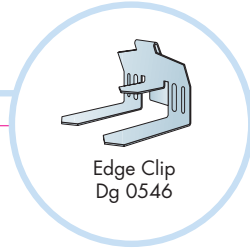
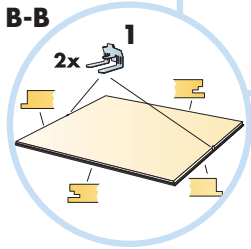

C-C

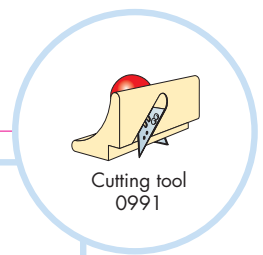
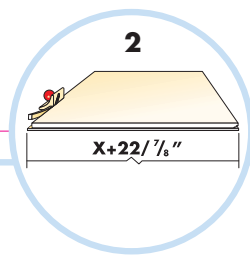
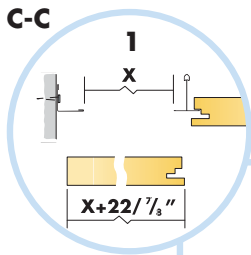

15

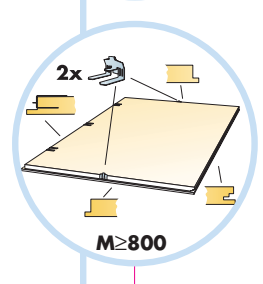
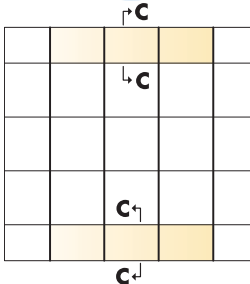

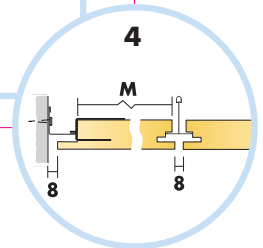
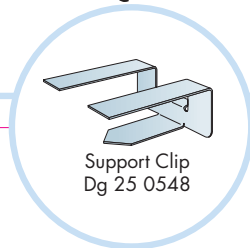
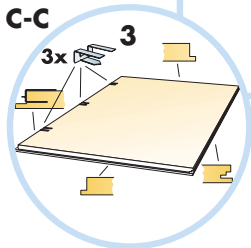

C-C

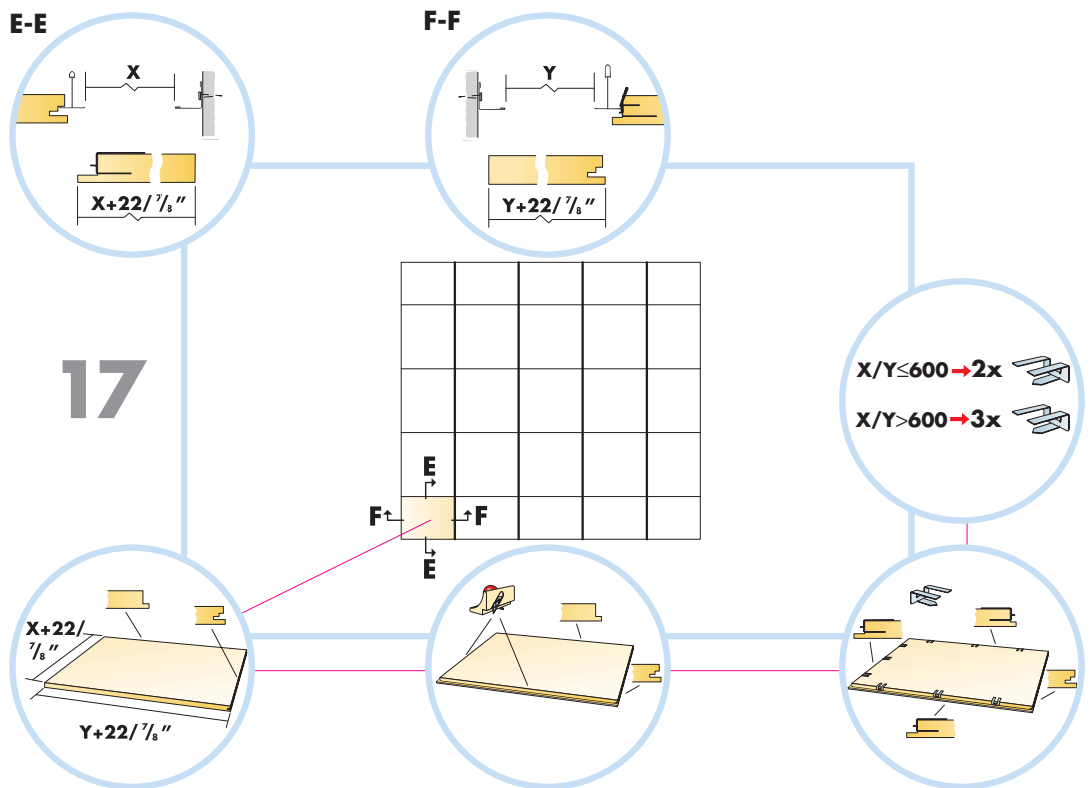
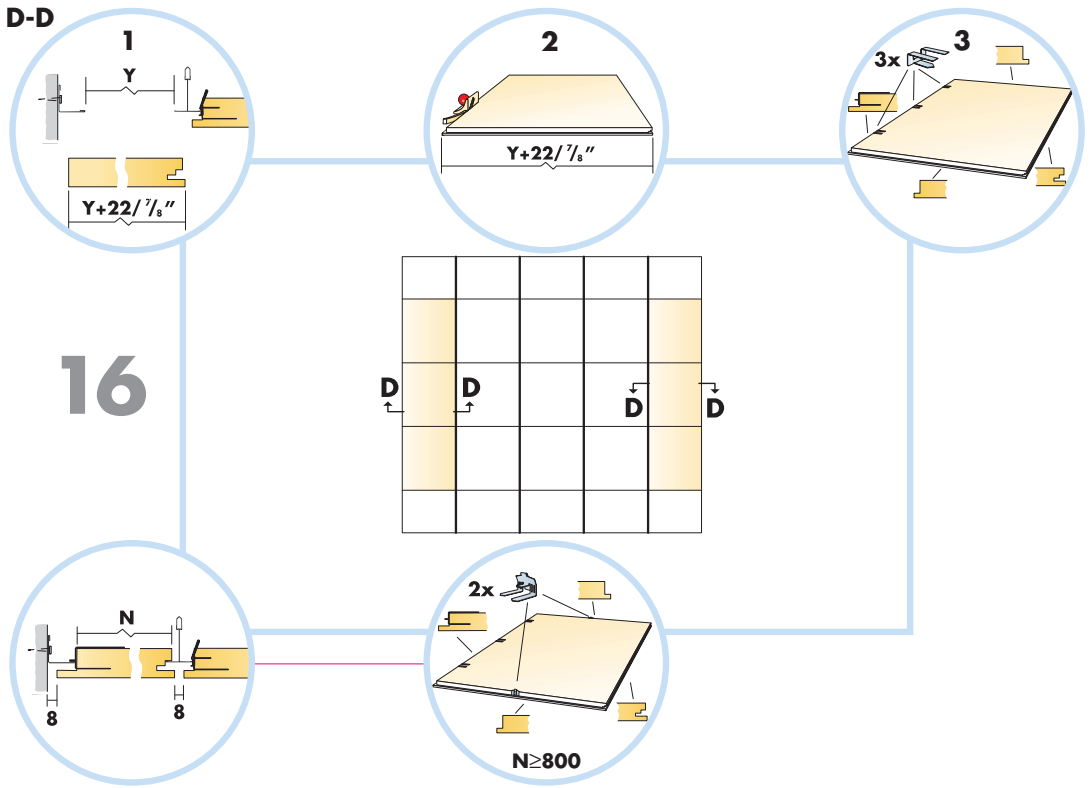

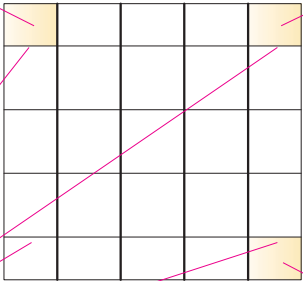
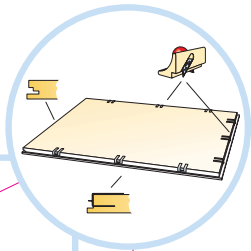
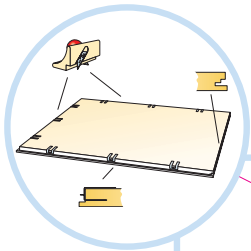

17¹



$X/Y \leq 600 \rightarrow 2x$ 
 $X/Y > 600 \rightarrow 3x$ 